

Application Note

AN-003

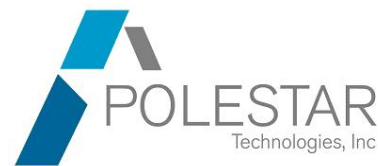

Single-use pH, O₂, and CO₂ Sensors: the iDOT™



The biopharmaceutical industry is showing a clear and growing trend toward single-use systems. Such systems offer obvious advantages in terms of convenience, set-up and cleaning time, reduction of validation burden, and cost savings. Evidence of this trend is seen in the adoption of single-use bioprocess vessels, in scales ranging from less than a liter to thousands of liters.

Despite obvious advantages, one challenge introduced by disposable vessels is the ability to monitor the processes occurring within them. Monitoring of bioprocesses has traditionally entailed either in-line sensors, or sampling for off-line analysis. The in-line approach is undesirable because of the risk of breakage with traditional glass electrodes, the risk of contamination when breaking into a sterile environment, and the inherent mismatch between single-use vessel and non-disposable electrodes. The off-line approach is undesirable because it is labor-intensive and precludes real-time readings. A need exists for robust single-use sensors for in situ process monitoring.

Disposables-compatible sensing platform enables in situ monitoring

The new integrated Disposable Optical Transducer (iDOT™) from Polestar Technologies (patent pending) provides an enabling single-use platform for routine optical monitoring in bioprocess disposables. Designed to work in conjunction with Polestar's existing DSP Series Optical Process Monitoring products, the iDOT™ provides an attractive alternative to traditional sensor probes for bioprocess disposables. Polestar's Class VI-certified sensing films can be attached to the iDOT™ without adhesives.

Gamma stable sensors minimize risk of compromising sterility

Sensor-enabled ports are welded into bags at the time of bag manufacture via the same process used to weld ports currently intended for fluid transfer. Sensing films can withstand gamma irradiation so the sensor can be installed into the bioprocess bag during bag production, then sterilized *in situ* with the bag. This eliminates the need to compromise bag sterility in order to insert a sensor probe after bag irradiation. Because the sensor is interior to the bag and the connection fitting external, the connection can be made at the time of use without compromising the sterility of the bag interior.

Compatible with Mass Customization Business Model

The Polestar iDOT™ fits the mass customization model currently prevalent in the bioprocess bag market. Bag producers would simply incorporate the appropriate sensor-enabled Polestar iDOT™ into the end-users' bags at the time of manufacture. End users simply connect the bag ports to a Polestar DSP Process Monitor via one of Polestar's standard optical cables.

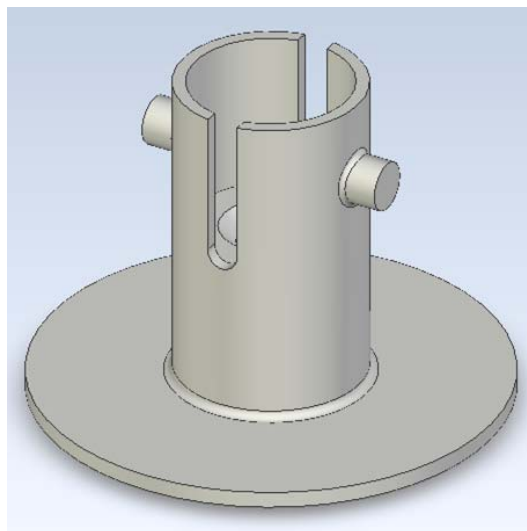

Integrated Disposable Optical Transducer (iDOT™):

- Enables non-invasive in situ monitoring of O₂, pH, or CO₂ in bioprocess disposables
 - without compromising sterility
 - without risking electrode breakage
- All materials USP Class VI-certified from sensor to bag port
- Welds directly to common bioprocess bag materials via large LDPE flanges
- Drops directly into existing bag port welding procedures at time of bag manufacture
- Withstands gamma sterilization
- Interfaces directly with Polestar DSP Series Optical Process Monitors via customized ST connectors
- Stores dry in bag for extended periods prior to use
- Fits with mass customization business model employed for most bioprocess disposables
- Marries the capability and reliability of Polestar’s robust, drift-free optical sensing technology with the convenience of disposable bioprocess bags
- Specifications:
 - Flange diameter: 1.5 inches
 - Flange thickness: 0.035 inches
 - Connector diameter: 0.342 inches
 - Melting point: 110-130° C (230-266° F)
 - Specific gravity (water=1): 0.915 – 0.930

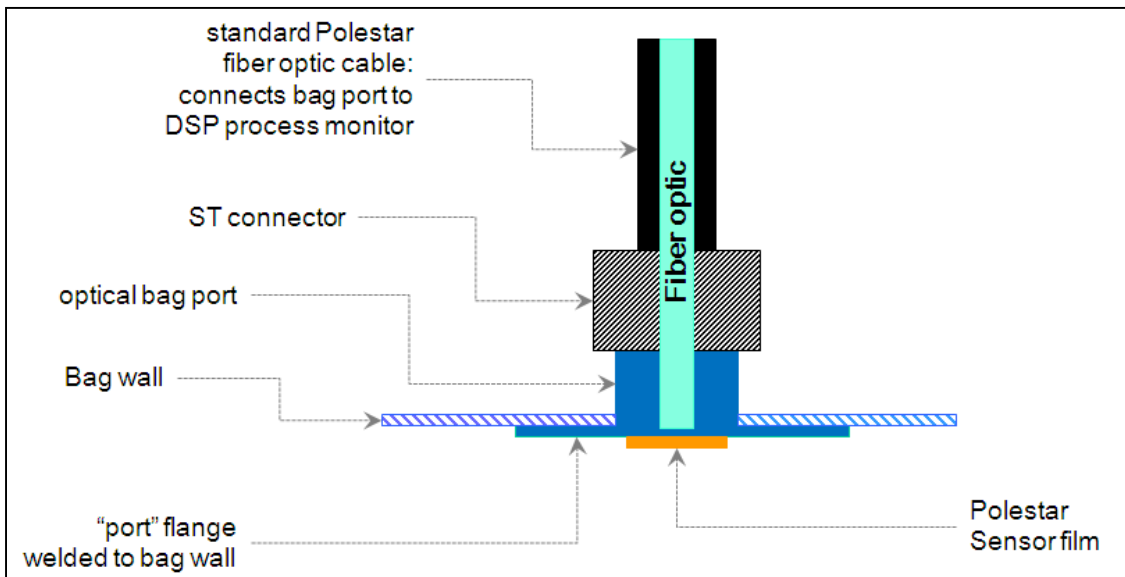

Schematic depicting Polestar Fiber Optic cable interfacing with iDOT™ welded into a single-use bioprocess bag.

For more information
 visit Polestar’s website at
www.polestartech.com;
 or contact Customer Service
 at 781-449-2284